



Cipher–Plexus Capital Advisors Pvt. Ltd.

www.cipherplexus.in

Overview

Cipher-Plexus Capital

Three Decades
of Experience



Led by Veteran
Deal Makers



15+ Team and
Partners with
Exceptional
Camaraderie



Track Record of
over 100+ Deals

- › Headquartered in Mumbai, Cipher-Plexus was formed with the integration of Cipher Capital & Plexus Ventures
- › Rich experience of three decades provides significant edge to protect & serve the best interests of its clients

- › Diversity of experience coupled with global reach & a culture founded on virtues enhances the ability to deliver superior value
- › 15+ Team members and Partners have been part of bulge-bracket investment banks

- › Insights from over 100+ successful transactions consummated across sectors, sizes, stages & complexities

Insights of over three decades and over 100+ successful deal closures ...

Business & Services

Private Equity

We enjoy a wide reach of high quality relationships and an admirable reputation with some of the most respected and sought after investors.

Our close interactions with all significant private equity and venture capital investors on an ongoing basis have helped us develop a deep understanding of their culture, functioning, investment philosophy and preferences. This facilitates the most appropriate investor-company fit towards delivering the best value in the given context.

Strong execution orientation & capabilities help us culminate difficult and complex transactions successfully & speedily.

Services Offered

- Growth/Expansion Capital
- Equity Financing
- Mezzanine Funding
- PIPEs
- Secondary Funding
- Special Situation Funding
- Buyouts
- Acquisition Financing

Select Transactions



Marck Biosciences
Pharmaceuticals - Sterile Liquids

Investment by
TATA CAPITAL
Private Equity

Tata Capital Healthcare Fund I



Adiga's Group
Quick Service Restaurants

Investment by
nsr | new silk route
GROWTH CAPITAL

New Silk Route



Sahyadri Hospitals
Multiple Specialty Hospitals

Investment by
IDFC

IDFC Project Equity



BGR Energy Systems
Turnkey Engineering & Equipment Supply

Investment by
citi

Citibank Private Equity



Warburg Pincus & Mahansarias
Off-Highway Tyres

Financial Advisor for Financing & Acquisition of
ATG
ALLIANCE TIRE GROUP

Alliance Tyre Company



MTR Foods
Processed Indian Food

Investment by
AQUARIUS
INVESTMENT ADVISORS PTE. LTD.
Aquarius (Singapore) & Associates



JMT Auto
Auto Ancillaries

Investment by
CHRYSCAPITAL

ChrysCapital



UEM Group
Water Treatment EPC

Investment by
INDIA VALUE FUND

India Value Fund



Balkrishna Industries
Specialty Tyres

Investment by
EVERCORE PARTNERS

Evercore



Rubicon Research
Pharmaceutical R&D and Outsourcing

Investment by
kotak
Private Equity

Kotak Private Equity Group



Atria Convergence Technologies
Digital Cable Distribution

Investment by
INDIA VALUE FUND

India Value Fund



Guardian Nutrition & Health Supplements
Wholesale Cash & Carry

Investment by
SAMARA CAPITAL

Samara Capital



Meghmani Organics Limited Ahmedabad, India
Agro-chemicals, Dyestuff and Intermediates

Investment by
Rajasthan Global Securities Pvt Ltd

Select Relationships

ASCENT CAPITAL



BARING PRIVATE EQUITY PARTNERS INDIA



THE CARLYLE GROUP



Creador®



EVERSTONE



Goldman Sachs



KKR



Morgan Stanley
Global Private Equity



MULTIPLES

NORWEST VENTURE PARTNERS



SAIFPartners®



SEQUOIA



TATA CAPITAL
Private Equity

TEMASEK



WARBURG PINCUS

Mergers and Acquisitions

We represent clients on the sell-side as well as buy-side leveraging our deep relationships, rich experience and insights in managing complex cross border and domestic transactions.

The team has a strong domain focus and knowledge of the ecosystem that coupled with our expertise in structuring help us unlock the true potential in each transaction. We work skilfully with a diverse set of banks, investors, other financial sponsors and agencies to consummate the transaction efficiently.

We have strong relationships in India, US, Europe, Japan, and Middle East which help in zeroing on to the right potential targets for the clients.

Services Offered

Domestic sell-side and buy-side transactions

Cross border M&A representing sell-side as well as buy-side

Divestitures and Spin-offs

Carve-outs

Strategic Alliances

Joint Ventures

Management Buy-outs

Leveraged Buy-outs

Management Buy-ins

Select Transactions

WARBURG PINCUS

Warburg Pincus & Mahansarias
Off-Highway Tyres

Financial Advisor, Financing & Acquisition of

ATG
ALLIANCE TIRE GROUP

Alliance Tyre Company

ecs

Electracard Services
Payments Technology & Processing

Strategic Investment by

Mastercard Worldwide

NUANCE

Nuance Communications USA
Speech Solutions

Acquired

Focus Infomatics, Inc.
A Healthcare Solution Company

Focus Infomatics

Windsor Sathyam

Wastewater Evaporator Manufacturing

Strategic Investment By

ARVIND

Arvind Group

Equinox Solutions USA
Software Solutions

Acquired by

CyberTech
The Difference is Depth™

Cybertech Systems

Bristlecone

Bristlecone Inc. USA
IT Consulting & Services

Majority holding acquired by

Mahindra
Mahindra Group

RIS

Result International Systems USA
IT Enabled Services

Acquired by

fiserv.
Fiserv Inc.

A D Electronics

Automation Product Distribution

Sole Financial Advisor for Acquisition by

REXEL
ELECTRICAL SUPPLIES

Rexel

CAREER LAUNCHER
Inspiring leadership

Career Launcher

Education, Training, Research & Consultancy

Acquired

KITS

Arun Roy Classes
Lohana Test Series
Compass Box
Law School Tutorials

Optimum Solutions
empowering business with technology

IT Solutions and Services

Investment by

ABeam Consulting

equinox

Equinox Corp. USA
Business Process Outsourcing

Acquired by

i-flex

iFlex Solutions

घड़ी

Ghari Group

Detergents & Soaps FMCG

Corporate Advisory

OGP
ORIENT GREEN POWER COMPANY LIMITED

Orient Green Power Company Limited
Chennai, India
Renewable Energy

Sale of Co-gen Power Plant to DY Patil

Structured Funding and Debt Advisory

Our Debt Advisory team specialises in providing advisory services across the full range of debt market including banking, capital market, asset-based lending, securitisation, project debt, senior debt, mezzanine financing, raising debt to finance LBOs or MBOs, acquisition financing and recapitalisation.

The team comprises veteran debt advisors with deep domain knowledge and understanding of the markets, this coupled with an extensive network of contacts with banks, financial institutions and other financial sponsors, provide solutions with optimal capital structures and most appropriate sources of finance.

Services Offered

- Syndication of Rupee Debt
- Foreign Currency Loan
- Acquisition Financing
- Project Finance
- Strategic Alliances
- Trade Finance
- Promoter Funding / ICDs
- Secured Loans
- Mezzanine Funding
- Asset Backed funding

Select Transactions



POWER
Atria Group, Bangalore

Structured Finance
Sole Arranger



Agrawal Group, Goa

Structured Finance
Sole Arranger



Asahi India

Rupee Term Loan
Sole Arranger



IPC Indo-Pharm
Chemicals
Private Ltd.

Structured Finance
Sole Arranger



Calcom Cement

Rupee Term Loan
Sole Arranger



PRATAP UNIVERSITY
Maharana Pratap
Education Society

Rupee Term Loan
Sole Arranger



PRATAP UNIVERSITY
Maharana Pratap
Education Society

Acquisition Finance
Sole Arranger



Asahi India

ECB
Sole Arranger

Domain Focus

Special Situation Funding

We are committed to assisting companies navigating through difficult operating and financial environments.

Our clients include companies, financial sponsors, lenders, creditors and other interested parties in financially stressed situations and distressed transactions. Our overriding goal is to help maximize the value of a financially distressed company while protecting the business interest of the client.

We bring problem-solving skills, multi-product transaction expertise, understanding of industry and access to various sources of capital that are important in getting the companies back on their own feet.

Services Offered

- One Time Settlement with lenders
- Corporate Debt Restructuring
- Restructuring & Re-financing
- Distressed M&A
- Sell off of divisions or recapitalisation
- Management Buy-Outs/ Buy-Ins
- Bridge Finance

Domain Focus

Cipher-Plexus operates across multiple domains, each with its own expert team and advisory partners. We have strong relationships with the top domestic and international companies as well as funds in each domain, ably led by a dedicated team of specialists with rich transaction experience within the sector.

Consumer and Agriculture



Energy & Environment



Healthcare and Life Sciences



Logistics, Shipping and Infrastructure



Manufacturing and Engineering

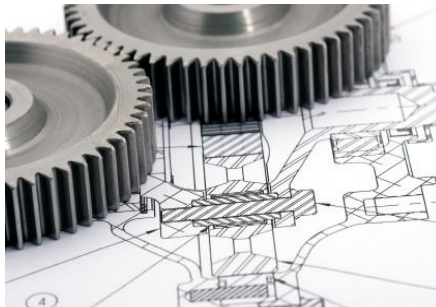

Technology, Media and Telecom



Consumer and Agriculture



Sub-sector focus

Food, beverages and restaurants

Specialty retail















Agri inputs and commodities

Home and personal care

Education

Consumer finance

Select Private Equity / Mergers and Acquisitions Transactions

 <p>A D Electronics Automation Product Distribution</p> <p>Acquisition by  Rexel</p>	 <p>Adiga's Group Quick Service Restaurants</p> <p>Investment by  New Silk Route</p>	 <p>MTR Foods Processed Indian Food</p> <p>Investment by  Aquarius (Singapore) & Associates</p>	 <p>CAREER LAUNCHER Inspiring leadership Career Launcher</p> <p>Education, Training, Research & Consultancy</p> <p>Investment by  Intel Capital</p>
 <p>CAREER LAUNCHER Inspiring leadership Career Launcher</p> <p>Education, Training, Research & Consultancy</p> <p>Acquired KITS Arun Roy Classes Lohana Test Series Compass Box Law School Tutorials</p>	 <p>Guardian Nutrition & Health Supplements Wholesale Cash & Carry</p> <p>Investment by  Samara Capital</p>	 <p>Ghari Group Detergents & Soaps FMCG</p> <p>Corporate Advisory</p>	 <p>Schroder Schroder Capital Partners Singapore</p> <p>Advisor for investment in  Vintage Cards & Creations (Greeting Cards)</p>















Environment and Energy



Sub-sector focus

- Energy generation
- Transmission and distribution
- Demand management
- Water management
- Solid waste management

Select Private Equity / Mergers and Acquisitions Transactions

 Aqua Designs India <i>Water Treatment EPC</i> <i>Investment by</i>  Peepul Capital	 BGR Energy Systems <i>Turnkey Engineering & Equipment Supply</i> <i>Investment by</i>  Citibank Private Equity	 Hydroair Tectonics <i>Water & Solid Waste Management</i> <i>Investment by</i>  Clearwater Capital Partners	 Atria Group <i>Renewable Energy IPP</i> <i>Investment by</i>  BanyanTree Growth Capital-II
 Iris Energy <i>Energy Efficiency Solutions</i> <i>Investment by</i>  108 Plexus	 Spray Engineering Devices <i>Energy Efficient Equipment</i> <i>Investment by</i> New Vernon & Klondike Investments	 UEM Group <i>Water Treatment EPC</i> <i>Investment by</i>  India Value Fund	 Windsor Sathyam <i>Wastewater Evaporator Manufacturing</i> <i>Strategic Investment By</i>  Arvind Group













Healthcare and Life Sciences

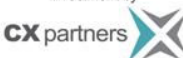

Select Private Equity / Mergers and Acquisitions Transactions

Sub-sector focus

- Hospitals
- Radiology and pathology
- Medical devices
- Drug discovery, CRO
- Pharmaceuticals Nutraceuticals,
- Biotech
- Sterile liquids, Chemicals Allied services

 <p>Sahyadri Hospitals Multi Specialty Hospitals</p> <p>Investment by  IDFC IDFC Project Equity</p>	 <p>Marck Biosciences Pharmaceuticals - Sterile Liquids</p> <p>Investment by  TATA CAPITAL Private Equity Tata Capital Healthcare Fund I</p>	 <p>NATCO Pharma Limited Integrated Pharmaceutical Company</p> <p>Investment by  CX partners CX Partners</p>	 <p>Rubicon Research Pharmaceutical R&D and Outsourcing</p> <p>Investment by  kotak Private Equity Kotak Private Equity Group</p>
 <p>HMD Hindustan Syringes & Medical Devices Medical Devices & Disposables</p> <p>Investment by Indocean Venture Advisors</p>	 <p>High Polymer Labs Specialty Chemicals</p> <p>Investment by  FRANKLIN TEMPLETON INVESTMENTS Templeton Asset Management</p>	 <p>Meghmani Organics Agrochemicals, Dyestuff & Intermediates</p> <p>Investment by JF Electra & ASC Capital</p>	 <p>Shasun Shasun Chemicals & Drugs Pharmaceutical API</p> <p>Investment by  GMO GMO</p>

Logistics, Shipping and Infrastructure

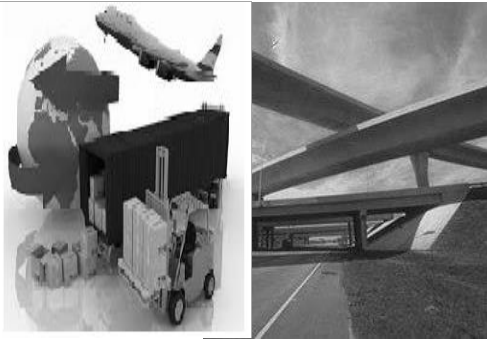

Sub-sector focus

- Roads
- Oil and gas
- Ports
- Metals and mining
- Airports
- Railways
- Real estate and hospitality

Select Private Equity / Mergers and Acquisitions Transactions

 IVRCL Infrastructures & Projects Ltd. IVRCL Infrastructure & Projects <i>Infrastructure Development</i> Investment by  Citibank Private Equity & Chryscapital	 IVRCL Infrastructures & Projects Ltd. IVRCL Infrastructure & Projects <i>Infrastructure Development</i> Equity Placement by Strategic Investors	 JUSCO Jamshedpur <i>Utility & Engineering Services</i> Corporate Advisory	 Pratibha Industries <i>Infrastructure Services</i> Co-advisor for investment by  Reliance Capital
---	--	--	--

Manufacturing and Engineering

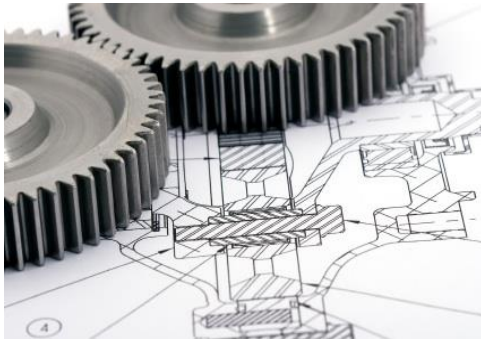

Sub-sector focus

- Construction equipment
- Defence equipment
- Automotive and auto ancillaries
- Capital goods
- Industrial chemicals and polymers
- Aerospace

Select Private Equity / Mergers and Acquisitions Transactions

 Balkrishna Industries <i>Specialty Tyres</i> <i>Investment by</i>  ChrysCapital	 Balkrishna Industries <i>Specialty Tyres</i> <i>Investment by</i>  Evercore	 Precision Automation & Robotics <i>Robotics Applications</i> <i>Investment by</i>  HDFC	 Precision Automation & Robotics <i>Robotics Applications</i> <i>Investment by</i>  SICOM & Private Investors
 Shriram Bearings (Subsidiary of SRF) <i>Ball Bearings</i> <i>Management buy-in by</i> Mr. P. C. Sen	 Shriram Needle Bearings <i>Needle Roller Bearings</i> <i>Acquired by</i>  NRB Bearings	 SRF Ltd. & Robotics <i>Industrial Synthetics</i> <i>Corporate Advisory & Restructuring</i>	 Warburg Pincus & Mahansarias <i>Off-Highway Tyres</i> <i>Financial Advisor for Financing & Acquisition of</i>  Alliance Tyre Company

Technology Media and Telecom



Sub-sector focus

Online services / digital media

IT services, KPO, BPO

Mobile VAS

Payments processing















IT distribution

Cloud computing

Media, cable distribution

Telecom infrastructure

Select Private Equity / Mergers and Acquisitions Transactions

 <p>ACT Atria Convergence Technologies Digital Cable Distribution</p> <p>Investment by</p>  <p>INDIA VALUE FUND India Value Fund</p>	 <p>Bristlecone Bristlecone Inc. USA IT Consulting & Services</p> <p>Majority holding acquired by</p>  <p>Mahindra Mahindra Group</p>	 <p>ecs Electracard Services Payments Technology & Processing</p> <p>Strategic Investment by</p>  <p>Mastercard Worldwide</p>	 <p>Equinox Corp. USA Business Process Outsourcing</p> <p>Acquired by</p>  <p>iFlex Solutions</p>
 <p>Equinox Solutions USA Software Solutions</p> <p>Acquired by</p>  <p>CyberTech The Difference is Depth™ Cybertech Systems</p>	 <p>Momentum technologies Momentum India Software Solutions</p> <p>Investment by</p>  <p>Citi Citibank Private Equity</p>	 <p>NUANCE Nuance Communications USA Speech Solutions</p> <p>Acquired</p>  <p>Focus Infomatics, Inc. A Healthcare Solution Company Focus Infomatics</p>	 <p>RIS Result International Systems USA IT Enabled Services</p> <p>Acquired by</p>  <p>fiserv. Fiserv Inc.</p>

Global Reach

Global Reach

We have a wide global presence via our network of close associates across India & abroad.

Our valuable cross-border relationships in Japan, Europe and the US help provide a wide global reach to our clients.

Exploring cross-border synergies in our work is of high priority to us and these relationships enhance our global outlook and reach for our clients.



Leadership Team

Leadership Team



Ravi Saxena

Co-Founder and Managing Director
B. Tech (IIT Delhi), MBA (IIM Ahmedabad)

Ravi founded Cipher Capital in 1994, one of the earliest entrants as a boutique Investment Bank focused on Private Equity and M&A Advisory space. Over the last two decades he has built a robust track record of successful deals and enduring relationships founded on strong values and ethics.

His versatility and positivity coupled with his strong leadership skills help provide Cipher-Plexus a solid foundation as an organisation.

Prior to founding Cipher, Ravi worked with companies like Bajaj Auto, Tata Motors and JM Financial. At JM Financial, he led assignments for some of India's largest corporations.



Kunal Kumthekar

Co-Founder and Managing Director
B. E. (C.O.E.Pune), PGDBA (IMDR, Pune), Alumni of Wharton Business School

Kunal has successfully closed a number of private equity and M&A transactions and led many investment opportunities as an investment banker & a professional investor. He has the rare advantage of having Buy as well as Sell side experience that gives him a significant edge in the ability to structure and close deals. He provides overall leadership in execution at Cipher-Plexus.

Kunal had founded Plexus in 2005 and was also a co-founder of Nine Rivers Capital, the firms have been in Investment advisory business and managed SEBI registered domestic fund as well as advised Mauritius based offshore fund. Kunal continues to be on the Board of some of the Investee companies and provides strategic insights to them.

He was a partner with Cipher from 1997 till 2004. Kunal started his career with JM Financial and grew to Head - M&A and Corporate Advisory group, and then to become the CEO of the entire broking business.

Team



Team



Mehul Ramchandra

Executive Director

B. Com (University of Mumbai), CA (ICAI, Mumbai), MBA – Finance (ISB Hyderabad)

Mehul is part of the senior management team and his key strengths are in building and maintaining relationships with clients & investors, executing transactions and regulatory understanding.

In his ~24 years of experience in investment banking and financial consulting, he has worked on several fund raising / strategic transactions and also consulted with various domestic and multinational organizations in their India related strategy.

Prior to joining Cipher, he worked with Andersen & EY.



Rajat Agrawal

Associate Director

B.Com (University of Mumbai), CA (ICAI, Mumbai), Executive MBA in Finance (NMIMS, Mumbai), CFA (CFA Institute USA)

Rajat has around 9 years of Business Development & Execution experience in Investment Banking, about 7 years of experience in Equity Research & 5 years of Industry Experience.

His core experience has been in domains across Consumer brands, NBFC's, Education, Industrials, Textile consumables, Hospitality, Solar power, Logistics, Healthcare, among others.

Prior to joining Cipher-Plexus, he was Vice President with Value Vision Consultants wherein his role comprised of both business development and execution. He has also worked with MX Capital as an Associate in Investment Banking

Team



Suresh Dhumale

Vice President

B.E-Chemical Engg. (UDCT, Mumbai), PGDM (IIM Ahmedabad)

Suresh has ~14 years experience in Investment Banking, Corporate Strategy & Finance with strong experience of transaction life cycle & many successful deal closures. He has closely worked with Top Management (CXOs) on various assignments from fund raising to process improvement to turnaround. Prior to joining us, Suresh was working with 7i Capital Advisors as AVP, and before that, with Veliing Holdings Ltd., Mauritius, Thomas Cook India, Gammon India Ltd., Digicable Network & BPCL.



Dhruv Saxena

Vice President

B Chem Engg., (UDCT Mumbai)

Dhruv has about couple of year's experience in Investment banking. At Cipher-Plexus he anchors start-ups and supplements business development and execution in PE, M&A space. He has 6.5 years of rich experience in the polymer industry coupled with having a strong overarching experience in the Oil & Gas/Energy space.

Prior to joining us, Dhruv has worked with ExxonMobil on various global assignments across different functions. He has worked very closely with senior management in financial planning for their flagship chemical business at their Houston Campus. He has also worked on the commercial side in the domestic Polyethylene market managing major markets of Daman and Tamil Nadu.



Abhishek Agrawal

Vice President

CA (ICAI), CFA (CFA Institute, USA), B.Com (Hons) (Calcutta University)

Abhishek has about 7 years of experience in Investment Banking with strong execution skills in IB and SME IPO and has worked across domains such as Consumer, Technology, Wellness, Engineering, etc.

Prior to joining us, Abhishek was working with Virtuous Capital Ltd as Sr, Associate working on end to end origination & execution of PE, M&A Transactions.

Team



Anand Mukunda Rajan

Assistant Vice President

MSc., Finance, (Imperial College, London), MA., (with Hons.)-Economics with Finance (The University of Edinburgh)

Anand has about 6 years of rich IB experience in Business Development and Execution in PE, M&A verticals in the Consumer, Healthcare & Pharma. He also supplements in the start-up space across sectors.

Prior to joining Cipher-Plexus, he interned with CIMB Investment Bank Pte Ltd, and before that India Infoline in their equity desk and JLT Asia Singapore Pte Ltd.



Akshat Gupta

Associate

BBA in Finance and International Business, (Christ University, Bengaluru), CFA-Level 1 (CFA Institute USA)

Akshat has about a year's IB experience in research analysis and execution.

Prior to joining Cipher-Plexus, he worked as an Investment Banking Analyst in Financial Institutions Group (FIG) department with Verity Knowledge Solutions Pvt Ltd.

He also previously interned with White Owl Ventures, PitchKrafts Consultant Pvt Ltd. & Food Vybe Technologies Pvt Ltd.



Varsha Phadke

Analyst

B.Com (University of Pune), MBA in Finance (Symbiosis University, Pune)

Varsha has interned with Cipher-Plexus for nearly a year having worked on various assignments in Business Development, Sector Landscapes, Desk Research, etc. and transitioned to the role of an Analyst in the company. She supports the core team in selective execution and business development research.

Contact Us

Cipher-Plexus Capital Advisors Pvt. Ltd.

Unit 1, Building 11, 1st floor, Solitaire Corporate Park,
Chakala, Andheri (E), Mumbai - 400093
Maharashtra, India

Tel: +9122 6777 4777 | Fax: +9122 6777 4778

Email: info@cipherplexus.in



● Mumbai Office

★ International Partners